

ENAGIC DUBAI

Company Profile

Change Your Water



Change Your Life!®

Enagic®



Enagic

KANGEN WATER®

Change your water, Change your life.



Congratulations and Welcome to

Enagic[®] Kangen Water[®] Equipment L.L.C.!

Dubai Branch

We are pleased that you have chosen Enagic as your business associate. It is indeed the first step towards success. Our aim is to provide you with crucial and beneficial information for you to feel proud to represent and share with others while pursuing Enagic business.





Enagic®

About Enagic

What makes Enagic different?

For over four decades, Enagic International has been the leader in manufacturing water- ionization systems that transform regular tap water into pure, healthy, electrolytically-reduced and hydrogen-rich drinking water.

This Japan-based company internationally distributes hundreds of thousands of Kangen Water® machines to homes all over the globe.

Enagic's Kangen Water® systems enhance nature's most vital life-source using the latest scientific research and technology, merged with superior Japanese craftsmanship.

Enagic International is the only water filtration and alkaline-ionizer distribution company in the world with its own OEM manufacturing facility in Japan and ISO certified quality control processes. All employees must master high-level technological knowledge and proficiency throughout the entire process, including development, production, supply, and service.

Company Culture, Personal Growth & Business Opportunity

The Enagic Corporation believes in empowering people through the direct-sales marketing system. Our independent and passionate distributors love to speak about the benefits of Kangen Water® to other as they build their own personal wealth.

Ours is a family that supports one another to achieve universal success. Our business opportunity has been sometimes referred to as "personal growth with a compensation plan", because we want our team to grow financially and as individuals.

As a result of this philosophy, our global distributors are able to achieve financial freedom and realize their dreams while promoting a product they believe in and truly love.



Global Events & Meetings

Connect, grow and learn with other Enagic® Distributors at the Enagic® Global Convention that takes place in Las Vegas every year.

Additionally, there are lots of localized opportunities to engage with Enagic® team members. Look for your nearest distributor sponsored event to get support and training from others that share the True Health spirit.



Corporate philosophy is based on three basic principles:

We all desire the same things in life. At the end of the day, we wish to be healthy, wealthy and happy.

Our corporate philosophy is based on three true health principals: -



1. Realizing **true physical health** through pure and healthy drinking water

2. Realizing **true financial health** through a wealth-developing business opportunity



3. Realizing **true mental/metaphysical health** through personal growth and finding contentment in all aspects of life.

Our purpose is spreading this tri-fold truth throughout the world.

When you commit to purchasing a product of this magnitude, it is your responsibility to find out all you can about the manufacturer, their corporate philosophy and customer service and the quality of the product. This is why we invite you to take a closer look at Enagic.



Made in Japan

Our machines are individually assembled by artisans and then inspected, tested, and certified by highly-trained QC engineers.

Get fast and efficient support from our experienced technicians and international service centers when needed. Always ask your water-ionization system provider for the kind of support service and warranty you will get from them.

CEO's MESSAGE

The Basis of Vitality and long life is WATER.

"Enagic celebrated its 47th year this year June as a specialized manufacturer of high-quality water ionizer generating systems. Today Enagic's pledge to realize a revolution in True Health - in the form of physical health, economic health and mental health - is supported by thousands of people around the world.

The human body is comprised of 70% water. It is no exaggeration to say that "the basis of vitality and long life is water." Enagic offers safe water that can be used with confidence to benefit health, beauty, sanitation and cuisine.

Enagic is an integrated development, manufacturing, sales and service company of alkaline ionizer technology.

As the evolution of information technology continues, we have entered the age of "human technology marketing." Market vitality now depends upon a merging of high technology and the personal relationship between human beings. Enagic is teaming up with an international network of offices and numerous distributors around the world to spread the word "water and health" while building a global company with worldwide operations."



Hironari Ohshiro

CEO Enagic International, Inc.

(2021)



About Enagic:

Year	Contents
1974	Sony's specialty trading operation, the precursor of Enagic®, began operations in Okinawa, Japan
1987	The Japanese Ministry of Health and Welfare authorizes of Enagic® Osaka factory as a medical equipment manufacturer
1988	Company became Kangen Water® specialist with philosophy of "True Health"
1990	The company change its name to Enagic®
1998	Tokyo Shinagawa Office opened. The 8-point system created
2000	Enagic® began sales of core product Leveluk® DX
2002	The Leveluk® series of Kangen Water® machines is solely recommended by the Japanese Association for the Prevention of Geriatric Diseases
	Enagic® Japan was established in Sapporo
	The Enagic® Service Division was established especially for the service and maintenance.
2003	Designated "Global Year One." International operations were initiated and Enagic® USA, Inc. was born
	The Leveluk® Super 501 and the ANESPA® models was released
	Enagic® USA was established in Los Angeles
	Enagic® Taiwan was established in Taipei. Enagic® USA was established in Hawaii Honolulu
	The Yanbaru Natural Materials factory is opened in Okinawa and production begins on Ukon® supplements
2004	The Yanbaru Natural Materials factory is registered as an FDA facility
	Kangen Ukon® is recommended by the Japanese Association for the Prevention of Geriatric Diseases
	Enagic® USA was established in New York
	Began sales of Kangen Ukon® Sigma
	Began sales of Leveluk® SD501
	Enagic® USA was established in Chicago
2005	The Leveluk® DXII and JR II models was released
	Enagic® Hong Kong was established
	The term KANGEN WATER® is trademarked in the United States
2006	Enagic® USA is enrolled as an official member of the Direct Selling Association (DSA)
	Enagic® Canada was established in Vancouver
	The Leveluk® Under-the-Counter model was released
2008	Enagic® Europe GmbH was established in Dusseldorf, Germany
	Enagic® forms an amateur baseball team



2009	The Enagic® Sports System, Inc. is established
	Enagic® de Mexico was established in Monterrey
2010	Enagic® Natural Hot Spring Aroma opened in Okinawa
	Enagic® USA was established in Dallas
	Enagic® Italy was established in Rome
	Enagic® Australia was established in Sydney
	The Enagic® Dual Pre-Filter System is released
	Enagic® Philippines was established in Makati City
2011	Enagic® Korea was established in Seoul
	Enagic® USA Service Center was established in Seattle
	Enagic® is granted trademark status for the exclusive 8-Point Business Model
	Enagic® receives WQA certification
	Enagic® USA was established in Florida
2012	Enagic® Singapore was established
	Enagic® Resort Golf Course opened in Okinawa
	Enagic® Canada was established in Toronto
	Enagic® Malaysia was established in Kuala Lumpur
2013	Enagic® Portugal Training Center was established
	Enagic® Thailand was established in Bangkok
	Enagic® Romania Training Center was established
2014	Enagic® Indonesia was established in Jakarta
	Enagic® Brazil was established in Sorocaba
	Enagic® Global Convention and 40th anniversary held in Okinawa, Japan
	The Leveluk® K8 models was released
	Enagic® Mongolia was established
2015	Enagic® Russia was established in Moscow
2016	Enagic® India was established in Bangalore
	Start selling Kangen Rice
	E8PA Grand Opening
2017	Enagic® Dubai was established
2019	Enagic® 45th anniversary
	Enagic® Japan was established in Fukuoka
	Enagic® Korea was established in Busan
2020	The Leveluk® JrIV model was released

KANGEN WATER®

AROUND THE WORLD



23 Countries, 40 Locations



Enagic®

About Factory

Innovative Water Technology

By integrating the latest scientific research and superior Japanese craftsmanship with nature's most vital resource for life, Enagic has pioneered the way of continuous Kangen Water® generating systems. Since 1974, Enagic has specialized in providing in-home, alkaline water ionization technologies. Our mission is to provide true health and wellness internationally with our Gold-Standard product line.

Enagic is proud to be one of the only water purification and ionization companies in the world that carries four distinct certifications from the Water Quality Association (WQA) - one of the oldest and most prestigious international not-for-profit trade associations in the world. The WQA has honored Enagic with the Gold Seal, a highly- distinguished award that is only given to the most reliable and trusted producers of quality drinking water. The level of excellence, quality, and care demonstrated by Enagic has set this leading company apart from every other water ionizer producer around the globe.

Factory appearance



Address: 1-40-1 Hoshida-kita, Katano City, Osaka, Japan 〒576-0017.

Tel: +81 72-893-2290



Plastic injection



Filter production



Machine_assemble



Metal process



Electric Circuit Detection



Water Detection



About Kangen Water®:

What is Kangen Water®?

Kangen means "return to origin" in Japanese. Kangen Water® is alkaline water produced by Enagic's alkaline ionizer and water filtration machines. For more than 40 years, Kangen Water® has been used in Japan to help restore the body to its original, alkaline state. These machines can transform your ordinary tap water into healthy, fresh tasting alkaline drinking water. Kangen Water® is superior to tap and purified water.

Kangen Water® has a negative oxidation-reduction potential or ORP.



Kangen Water® does not remove many minerals that are lost in the process of purifying bottled water.



By choosing to drink alkaline water, you aid your body in returning to a balanced state. Kangen Water® is a fresh, clean and great tasting way to obtain optimal health!





Properties of Kangen Water®:

Active Hydrogen Rich

Through the process of electrolysis, your tap water becomes Active Hydrogen (OH-) rich Kangen Water®. Kangen Water® is high concentration of Active Hydrogen (OH-). It is an efficient antioxidant that diffuses rapidly across cell membranes and can reduce free radicals, suppressing oxidative stress.

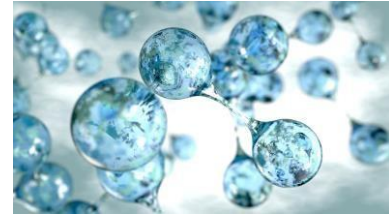

Negative ORP (Oxidation-Reduction Potential)

Active Hydrogen rich water is characterized by exhibiting a negative ORP. A high ORP value (in positive numbers), indicates that a substance has a higher oxidizing potential. In generalized terms, for humans a positive or high ORP is better for the outside of the body (cleaning and sanitizing).

A low ORP value (in negative numbers) indicates that a substance has a higher anti-oxidizing potential, and is preferred for oral consumption.

Just like pH, ORP values are an important measurement for determining the quality of water.



Alkaline

As with most things in life, optimal health begins with balance. Our bodies must maintain a pH balance of 7.365, which is slightly alkaline. A pH scale is used to determine whether a substance is acidic or alkaline. On this scale 7.0 is neutral. Anything above 7 is considered alkaline and anything below 7 is considered acidic.

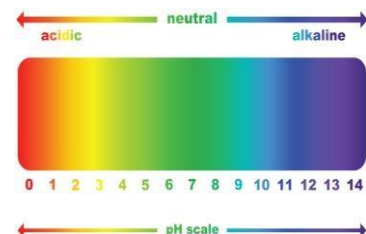



About the benefits of electrolyzed water:

Strong Kangen Water®

pH 11.5  not for drinking
Hygiene, cleaning

Food preparation

Remove pesticides, preservatives and chemical (rinsing with acidic water can prevent food poisoning). Food will be more umami and delicious after washing with Strong Kangen Water®.

Remove Oily Dirt

Good for cleaning oil and tough grime from vents, stove, great for getting out stubborn toilet bowl stains, will remove coffee, soy sauce, and oil stains with ease. Use less detergent when washing your dishes. Save on water bills.

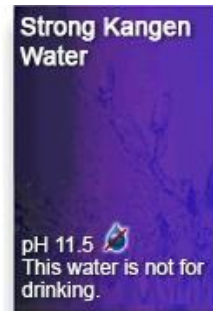



Kangen Water[®] pH8.5-9.5 drinking Healthy Water Health Care Body Conditioning

Daily Drinking

It is recommended to drink Kangen Water[®] daily, which is rich in minerals and active hydrogen, which can effectively eliminate the main sources of human diseases: acids and active oxygen free radicals. Long-term drinking can help to prevent and treat diseases.



Brew Tea and Coffee

Its solubility can make the brewed tea and coffee brighter in color and richer in flavor, which can reduce the amount of tea leaf and coffee beans.

Cooking

It is used to wash rice and cook rice, which can make the rice softer and delicious, and it is not easy to change color and deteriorate.

Washing vegetables before cooking, can remove the astringent taste of burdock, onion, bamboo shoots, ferns, aster... etc., making the vegetables less yellow. Washing meat, soaking and then washing can easily remove blood impurities and fishy smell. When cooking with Kangen Water[®], the flavor of the ingredients can be fully released, and they can be cooked quickly and easily without putting too much seasoning and saves energy.





Neutral Water pH7.0 drinking

Pure natural water

Taking medication and Preparing Baby Food

The multi-layered high-performance filter element removes many residual substances in the water, such as chlorine, odor, etc. It is natural pure water, suitable for taking medicine, preparing baby food and milk.





Acidic Water pH4.0~6.0 not for drinking

Beauty, Disinfection

Beauty Water

The astringent effects can tighten skin pores and moisturize. Adding bath water when taking a shower can promote body insulation. Use as a conditioner when shampooing for smooth, shiny hair and pet care.

Cooking noodle, Fried Food, Frozen Food

Can make noodles more refreshing. The preparation of fried foods can make fried foods crunchier and more delicious, and not easily soften. Spray foods with Acidic Water when freezing so that the food, including fish and shrimp, do not lose its flavor when thawed out.

Cleaning, Polishing

Remove dirt from hardwood floors, ceramic tiles etc. without leaving a sticky residue. Polish mirrors, eyeglasses, glass objects, and windows to a high sheen.





Strong Acidic Water pH2.5 not for drinking

Disinfection, Hygiene



Sanitize Kitchen Utensils

Sanitize knives, cutting boards, dish towels, and kitchen cloths etc. (rinse with Strong Reduced Water[®] before washing with Strong Acidic Water for more effective sterilization). However, as the acidic is strong, please wipe and dry out the metal utensils completely.

Personal Hygiene, Home Disinfection, Commercial Operation

Disinfect your hands, your toothbrush or as mouth wash. Keep a spray bottle in your bathroom and toilet for easy access. It can also be widely used for skin problems, wound care, oral disinfection, bathing, to prevent cross-contamination and cleaning pet hair. Beauty salons, hair salons, restaurants, daycare centers, pet shops, and school all benefit greatly from the use of Strong Acidic Water.

***The pH value depends on the local water source, water storage and water pipes of the building, the per-filter of the water machine, and the maintenance of the water machine.**



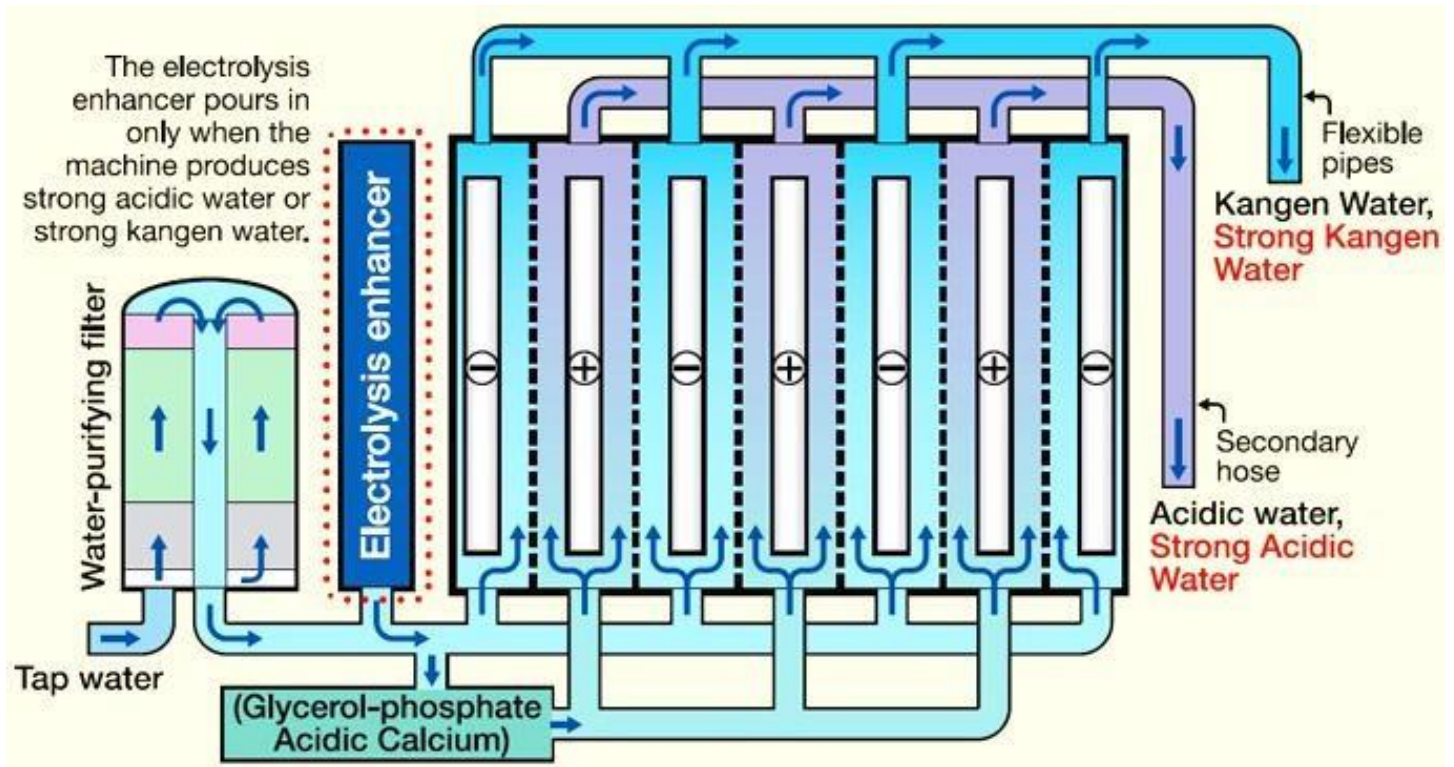

The Electrolysis Process:

STEP 1: FILTRATION the internal High-Grade Filter filters chlorine, unpleasant taste and odor, and reduces sediments up to 5 micrometers to produce Clean Water.

Your use of external Pre-Filtration systems does NOT substitute for the necessity to use the special Enagic HG filter installed in the used device, and to replace it periodically, in order to ensure the quality of the water resulting from the electrolysis process.

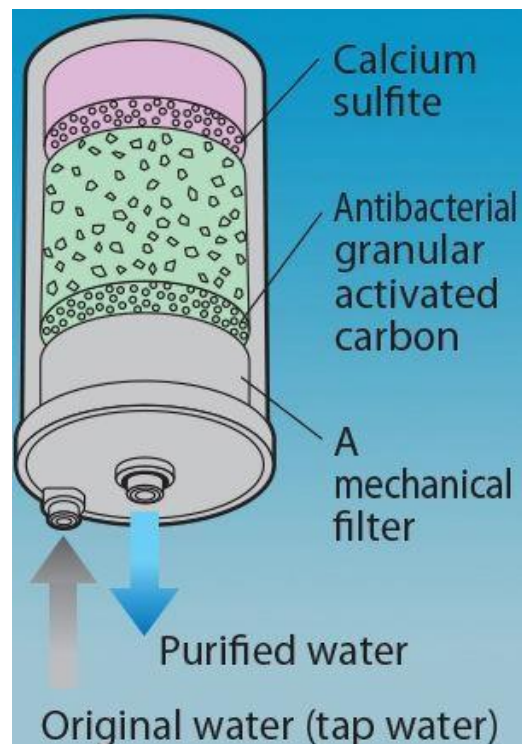

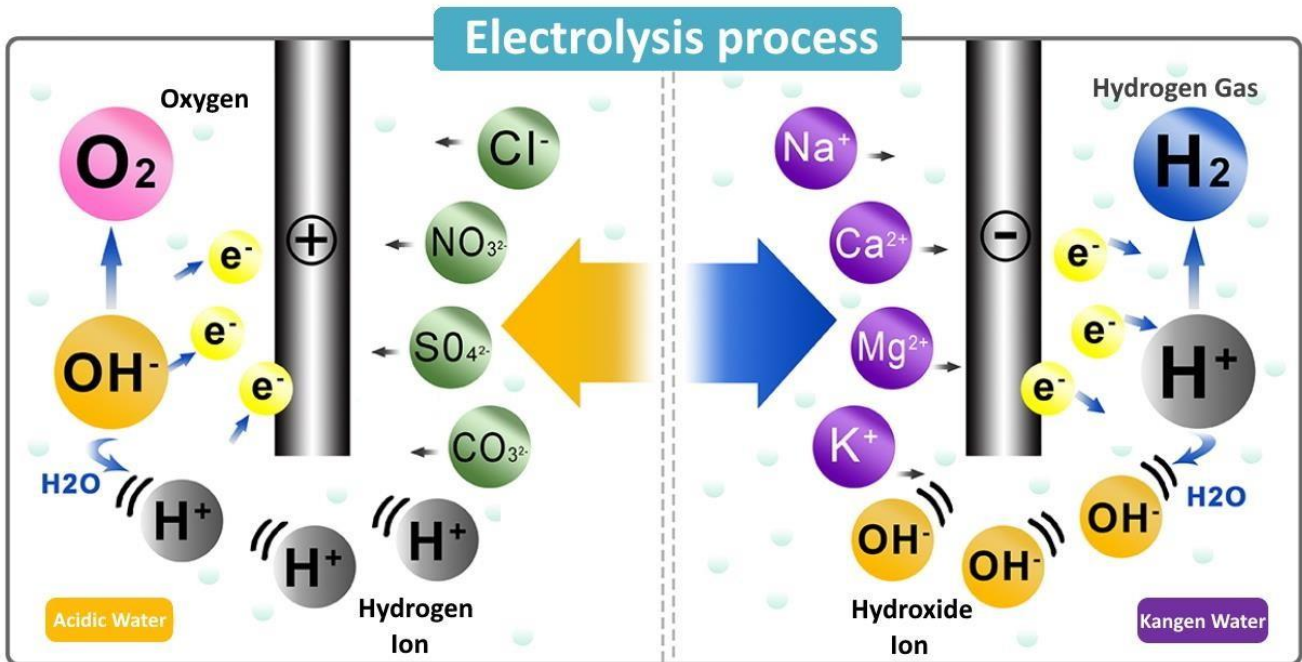

STEP 2: ELECTROLYSIS through several* electrode plates and membranes, the filtered water is separated into acidic and alkaline parts. Water is split into OH^- (hydroxide ions) and H^+ (hydrogen ions). The hydrogen ions react with electrons given by the cathode (– charged electrode), forming H_2 , molecular Hydrogen. Hydroxide ions remain, making the water more alkaline around the cathode. Conversely, close to the anode (+ charged electrode), hydroxide ions give electrons to the anode, eventually forming O_2 (Oxygen). Hydrogen ions remain, making the water more acidic around the anode. The two kinds of water are separated by membranes and released through different hoses.

*number depending on machine model.



Which Kangen Water® machine
is right for you?





THE MIGHTY 8-PLATES ANTI-OXIDIZER

LEVELUK® K8





Enagic®

LEVELUK® 8 (K8)

Electrolysis cell with 8 electrode plates ensures high power.

A clear, easily viewable, large LCD with a touch panel makes it easy to operate.



1. Electrolysis cell with 8 electrode plates ensures high power.

A clear, easily viewable, large LCD with a touch panel makes it easy to operate.

It is possible to produce a good amount of electrolyzed water of which the value of ORP is included in the range of +1130mV and -800mV and which boasts of good effects. The Kangen Water® contains a lot of hydroxide ions (OH-) and positive ions (such as calcium ions) produced by electrolysis, and it also contains hydrogen. (That depends on the choice of resulting water and original water)

2. A clear, easily viewable, large LCD with a touch panel makes it easy to operate.

You will be notified by a large-sized liquid crystal display (LCD) and the voice promoted guide. Easy to use touch screen.

A clear, easy viewable, large-sized LCD and voice prompts shows you of the water being produced (Kangen Water®, Acidic Water, Strong Acidic Water*, or purified water) and other necessary information. The operation is very easy. Introduction of a touch screen panel has greatly enhanced ease of operation.

*When you push the button for Strong Acidic Water, the secondary hose releases Strong Acidic Water and the flexible pipe releases Strong Kangen Water® at the same time.

3. With 8-language display and voice prompt, you can use it with ease.

For display and voice prompt, you can select from 8 languages: Japanese, English, French, German, Chinese, Italian, Spanish, and Portuguese (voice prompt changes automatically upon change of language display).

4. Supporting multi-voltage power input, can be used anywhere in the world.

This product supports multi-voltage power input that can be used anywhere in the world (accompanying power-supply cord varies depending on the country of use).



THE ULTIMATE HOME USE MODEL PLATINUM

LEVELUK® SD501 PT





Enagic®

SD501 Platinum

Used and loved throughout 82 countries, the Leveluk® SD501 Platinum now comes in ONE machine capable of speaking all notifications in FIVE languages! (*English, German, French, Italian, Spanish*)

By simply, and conveniently selecting the language of your choice, the new Platinum will change to that language! It has seven electrode plates to ensure sufficient power. It is easy to use and compactly designed.



1. The electrolytic cell is equipped with seven electrode plates, which is powerful and compactly designed.

It is possible to produce a good amount of electrolyzed water of which the value of ORP is included in the range of +1130mV and -800mV and which boasts of good effects. The Kangen Water® contains a lot of hydroxide ions (OH-) and positive ions (such as calcium ions) produced by electrolysis, and it also contains hydrogen. (That depends on the choice of resulting water and original water)

2. Equipped with an electrolysis enhancer tank, Strong Acidic Water and Strong Kangen Water® produced steadily and continuously.

The built-in tank for the electrolysis enhancer saves you the trouble of putting in the electrolysis enhancer which is necessary to obtain Strong Acidic Water and Strong Kangen Water®. It allows you to produce those kinds of water steadily and continuously that has excellent effects. An injection of electrolysis enhancer (400g) produces around 20~30 liters of Strong Acidic Water in around thirty minutes. (This figure depends on the water quality)

3. You will be notified by a large-sized liquid crystal display (LCD) and the voice promoted guide. Easy to use one-touch panel.

A clear, large-sized LCD and voice prompts will inform you of the water being produced (Kangen Water®, Acidic Water, Strong Acidic Water*, or purified water) and necessary information. The operation is very easy, because you only need to touch a button in order to power up or down or to select the type of water you would like to obtain.

*When you push the button for Strong Acidic Water, the secondary hose releases Strong Acidic Water and the flexible pipe releases Strong Kangen Water® at the same time.



Enagic®

THE ULTIMATE HOME USE MODEL

LEVELUK® SD501





Enagic®
SD 501

It has seven electrode plates to ensure sufficient power. It is easy to use and compactly designed.

- 1. The electrolytic cell is equipped with seven electrode plates, which is powerful and compactly designed.**



It is possible to produce a good amount of electrolyzed water of which the value of ORP is included in the range of +1130mV and -800mV and which boasts of good effects. The Kangen Water® contains a lot of hydroxide ions (OH-) and positive ions (such as calcium ions) produced by electrolysis, and it also contains hydrogen. (That depends on the choice of resulting water and original water)

- 2. Equipped with an electrolysis enhancer tank, Strong Acidic Water and Strong Kangen Water® produced steadily and continuously.**

The built-in tank for the electrolysis enhancer saves you the trouble of putting in the electrolysis enhancer which is necessary to obtain Strong Acidic Water and Strong Kangen Water®. It allows you to produce those kinds of water steadily and continuously that has excellent effects. An injection of electrolysis enhancer (400g) produces around 20~30 liters of Strong Acidic Water in around thirty minutes. (This figure depends on the water quality)

- 3. You will be notified by a large-sized liquid crystal display (LCD) and the voice promoted guide. Easy to use one-touch panel.**

A clear, large-sized LCD and voice prompts will inform you of the water being produced (Kangen Water®, Acidic Water, Strong Acidic Water*, or purified water) and necessary information. The operation is very easy, because you only need to touch a button in order to power up or down or to select the type of water you would like to obtain.

*When you push the button for Strong Acidic Water, the secondary hose releases Strong Acidic Water and the flexible pipe releases Strong Kangen Water® at the same time.



ENAGIC'S MOST POWERFUL MODEL!

LEVELUK[®] SUPER 501





Enagic®
Super 501

As for the cell of electrolysis by which the water for the health administration of drinking water, cosmetics water, washing, and disinfection is generated from two hose, exclusive use was benefited by the hose, respectively for exclusive use in each. Create generous quantities of Kangen Water® and Strong Acidic Water.



For Super Heavy Use

This powerful Enagic machine is a large family unit, and the top of the line model for heavy home use or for small businesses. Nursing homes, agricultural colleges, and spas can all benefit greatly by having the high-performance Super501! Generates: Strong Kangen Water®, Kangen Water®, Neutral Water, Beauty Water, and Strong Acidic Water.

12Titanium Plates

With 12 platinum-coated 99.97% pure titanium electrode plates, this highly productive machine generates all 5 different types of Enagic water (see below) for countless uses around your home or business. If you're looking for a super-sized SD501, the Super501 is exactly what you need.

In order to produce Strong Acidic Water and Strong Kangen Water®, the electrolysis enhancer (salt solution) must be added. About 120 liters Strong Acidic Water (about 80 minutes) can be produced by using the enhancer in the internal tank at one time. Continuous use is possible if replenished. Automatic cleaning can be performed even while it is being used and water can be stored in the external tank.

Super Easy to Use

With just a touch of a button, you can have access to any of the 5 waters you choose. Your machine will confirm the water you have selected, and in moments the machine will generate healthy, ionized water. Your SUPER501 will even notify you when it's time to change the water filter via a message on the LCD Panel and a buzzer sound.

Industrial Strength

The Super501 features the same quality built-in electrolysis enhancer tank as the SD501, and can generate up to 2 gallons of water a minute for approximately 30 minutes at a time, so you will never run out of the water you need to run your business. This hefty machine also boasts 2 flexible pipes - one specifically designed for Kangen Water® and the one for Beauty Water.



THE ENERGY SAVER

LEVELUK® JRIV



**THE ENERGY
SAVER**

[Visit Our Store](#)



Strong Acidic Water and Strong Kangen Water® produced steadily. The type of energy conservation.

1. Equipped with four high quality electrode plates.

It is possible to produce a good amount of electrolyzed water with the ORP value in the range of +1130mV and -800mV and which boasts of good effects. This design is made possible by loading an electrolytic cell with four electrode plates that use electrodes made of platinum plated titanium.



2. Equipped with an electrolysis enhancer tank, Strong Acidic Water and Strong Kangen Water® produced steadily and continuously.

The built-in tank for the electrolysis enhancer saves you the trouble of putting in the electrolysis enhancer which is necessary to obtain Strong Acidic Water and Strong Kangen Water®. It allows you to produce both kinds of water steadily and continuously. An injection of electrolysis enhancer (400g) produces around 10~15 liters of strong acidic water in around thirty minutes.

3. You will be notified by a large-sized liquid crystal display (LCD). Easy to use one-touch panel.

A clear, large-sized LCD will inform you of the water being produced (Kangen Water®, Acidic Water, Strong Acidic Water*, or purified water) and necessary information. The operation is very easy, because you only need to touch a button in order to power up or down or to select the type of water you would like to obtain.

*When you push the button for Strong Acidic Water, the secondary hose releases Strong Acidic Water and the flexible pipe releases Strong Kangen Water® at the same time.



MINERAL ION WATER SPA

ANESPA[®] DX





Enagic®
ANESPA® DX

The NEW exclusive ANESPA® DX Home Spa System transforms your ordinary bathroom into a natural hot spring resort, excellent design easy for replace filter.

Removes Harmful Substances

The high-quality ceramic cartridge purification system effectively removes chlorine, rust and dirt, leaving you with a fresh, invigorating feeling. Protect your delicate skin from the harmful effects of tap water. Active charcoal filter and Futamata-ceramic inner filter.



Mineral Ion Water

Contains a blend of natural hot spring ingredients and minerals, giving you the feeling that you're enjoying a pleasant hot spring and taking advantage of the mineral ion water. Relax and Enjoy!



Tufa

A mineral stone taken directly from the Futamata Radium Hot spring in Hokkaido, Japan. This stone gives the water the same gentle and relaxing effect of a hot spring.

MIC stone

Rich in Minerals as it is made up of more than 25,000 different minerals, absorbing toxic substance and regulates the water quality.

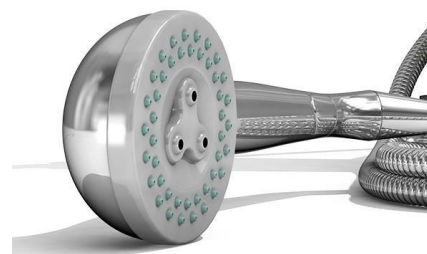

Power stone

Generates strong negative-ions.



Enagic®

Machines Display

	Machine Model	Water Type	pH Range	ORP	Weight	Plates & Wattage	Warranty
	K8	5 Types	2.5 ~ 11.5	- 850	5 Kg	8 Plates 110 ~ 240 W	5 Years
	SD 501	5 Types	2.5 ~ 11.5	- 800	6 Kg	7 Plates 220 ~ 240 W	5 Years
	SD 501 Platinum	5 Types	2.5 ~ 11.5	- 800	6 Kg	7 Plates 220 ~ 240 W	5 Years
	Super 501	5 Types	2.5 ~ 11.5	- 800	10.1 Kg	5 & 7 220 ~ 240 W	3 Years
	JRIV	5 Types	2.5 ~ 11.5	- 450	5.3 Kg	4 Plates 220 ~ 240 W	3 Years
	ANESPA® DX	1 Type	Same as Tap Water	N/A	2.6 Kg	N/A	3 Years

MENTIONED pH & ORP DEPEND ON THE WATER QUALITY AND FLOW RATE



Enagic Marketing Plan

The basic 8-points commission structure

There are 6 ranks (1A ~ 6A) and all ranks have 8 levels to pay

This structure works the same for all products, although the commission point value varies for each product. The basic 8-points commission structure is the foundation from which each distributor begins building with Enagic product sales.

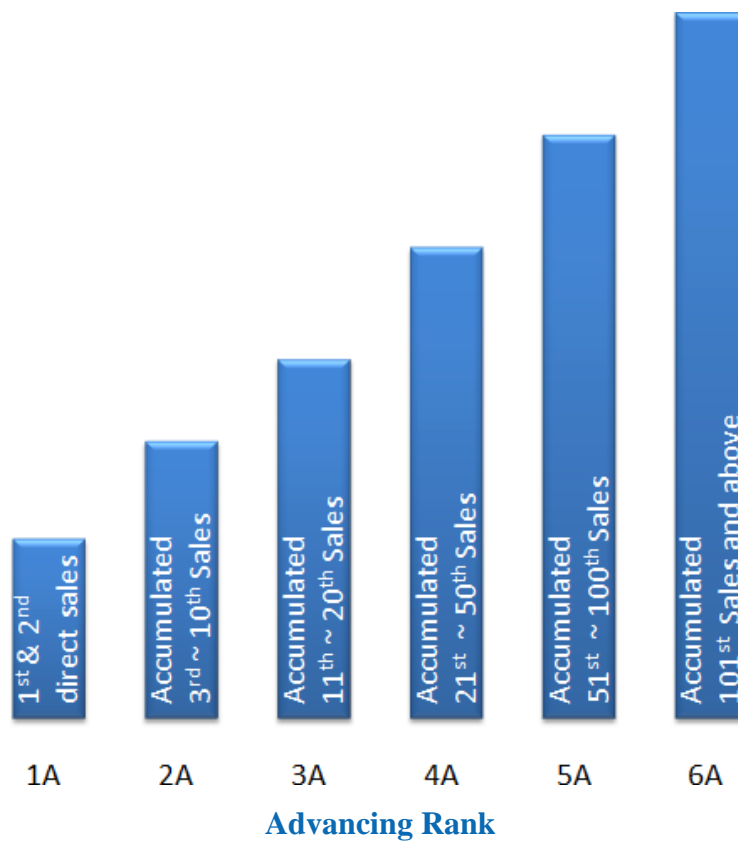

Rank advancement is based on combination of direct and group sales, and it is NOT necessary to advance one rank at a time. **An advance in rank is always initiated by a direct sale**, but a distributor will advance to whichever rank he is qualified for based on total accumulated sales volume. Once a rank achieved, it will be retained until the next rank is attained. There will be no need for a distributor to start over and distributors ranked 2A and higher can have an unlimited number of direct sales.

The following are the requirements for each rank



1A Distributor

Qualification to achieve this rank:

- Personally, sell one unit (a unit sold to one self is counted as a sale)
- Each direct sale made as a 1A represents a new 1A team selling beneath you

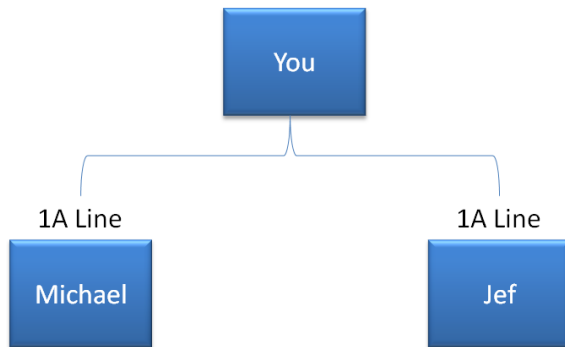

- Michael and Jef will be your 1A line
- You will receive overriding maximum of "1 point" from this line

2A Distributor

Qualification to achieve this rank:

- You must be 1A distributor first.
- Accumulated direct sales for 2 units.
- You will be paid as a 2A distributor upon making your 3rd direct sale.
- Each direct sale made as a 2A represents a new 2A team selling beneath you

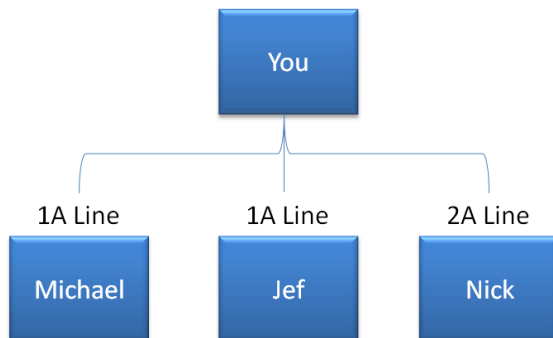

- Nick will be your 2A line
- You will receive overriding maximum of "2 points" from this line



3A Distributor

Qualification to achieve this rank:

- Accumulated total sales for 10 units. (direct and indirect)
- You will be paid as a 3A distributor upon next direct sale.
- Each direct sale made as a 3A represents a new 3A team selling beneath you

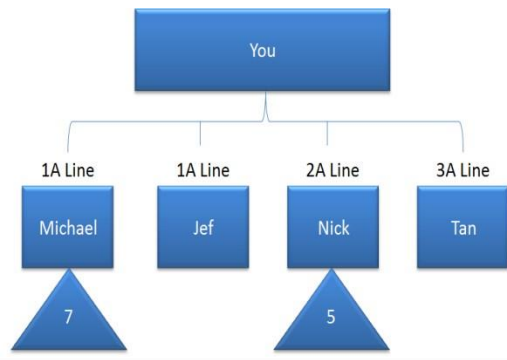

- Tan will be your 3A line
- You will receive overriding maximum of "3 points" from this line

4A Distributor

Qualification to achieve this rank:

- Accumulated total sales for 20 units. (direct and indirect)
- You will be paid as a 4A distributor upon next direct sale.
- Each direct sale made as a 4A represents a new 4A team selling beneath you

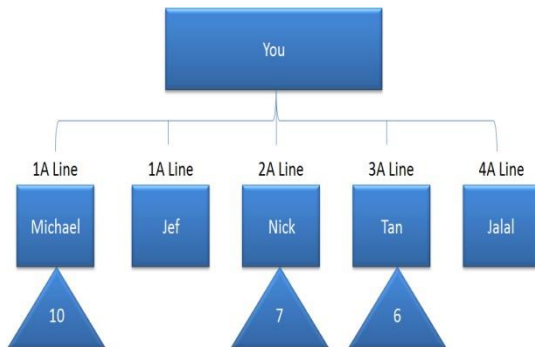

- Jalal will be your 4A line
- You will receive overriding maximum of "4 points" from this line



5A Distributor

Qualification to achieve this rank:

- Accumulated total sales for 50 units. (direct and indirect)
- You will be paid as a 5A distributor upon next direct sale.
- Each direct sale made as a 5A represents a new 5A team selling beneath you

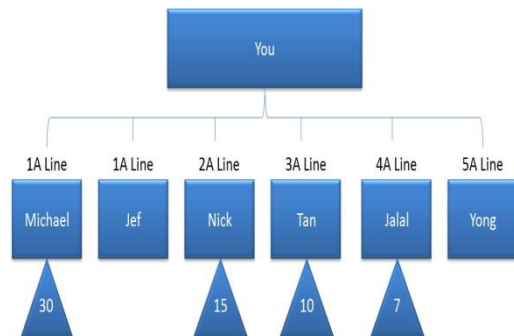

- Yong will be your 5A line
- You will receive overriding maximum of "5 points" from this line

6A Distributor

Qualification to achieve this rank:

- Accumulated total sales for 100 units. (direct and indirect)
- You will personally sell one additional unit to be paid as this rank.
- Each direct sale made as a 6A represents a new 6A team selling beneath you

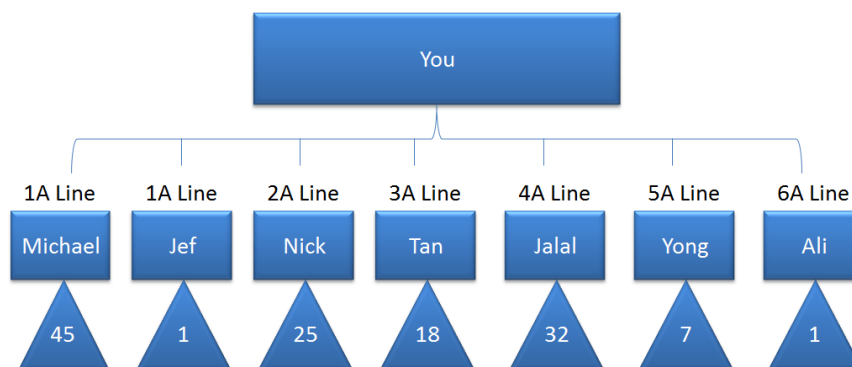

- Ali will be your 6A line
- You will receive overriding maximum of "6 points" from this line



8-points Commission Structure

The Basic 8-points commission Structure is the foundation from which each distributor begins building his/ her financial health with Enagic.

The following explains how a distributor achieves each rank's advancement and the maximum they are eligible to earn at each rank of "1A" through "6A". For simplicity, all examples shown here use the commission point value of the K8, our most popular unit. Each point for this product has a value of AED 1,250.00.

A total of 8-points are paid out on each product sale and the number of points paid to a distributor is based on his/ her rank. A distributor at rank of 1A will be paid one point; 2A distributor will be paid 2 points, and so on. For the K8, the total pay-out for each product sale is $AED\ 1,250.00 \times 8 = AED\ 10,000.00$.

Commission pay-out always begins with the distributor that made the sale and is paid out up-line from that point until all 8-points have been awarded.

i.e. You are 1A distributor

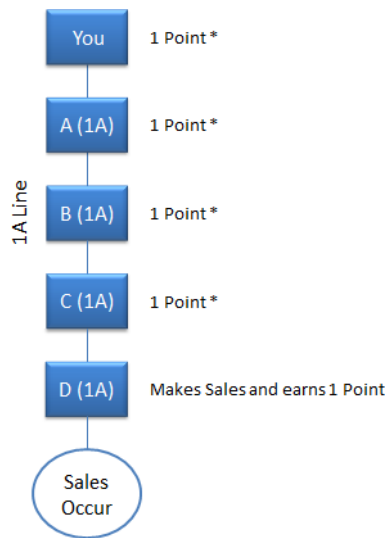

1A Distributor Example

i.e. You are 2A distributor

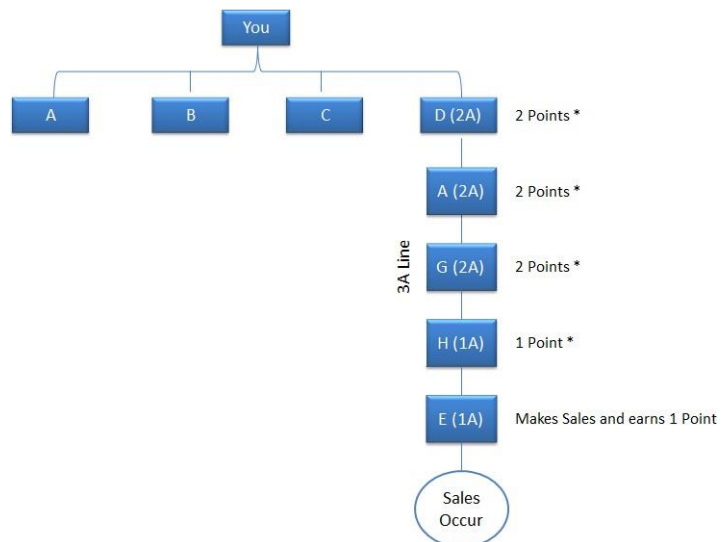

2A Distributor Example

* Kindly refer to Enagic commission chart for more information about points.



Sponsor's Rules

You should register all your accounts under only one sponsor ID, and you can NOT register under several different IDs even if it relates to the same person

When you are willing to open yourself 2nd and 3rd distributorship account, these accounts will be opened as a distributor IDs under your existing distributor account ID (YOU#1), NOT under your sponsor ID.

Examples: -

i.e. #1

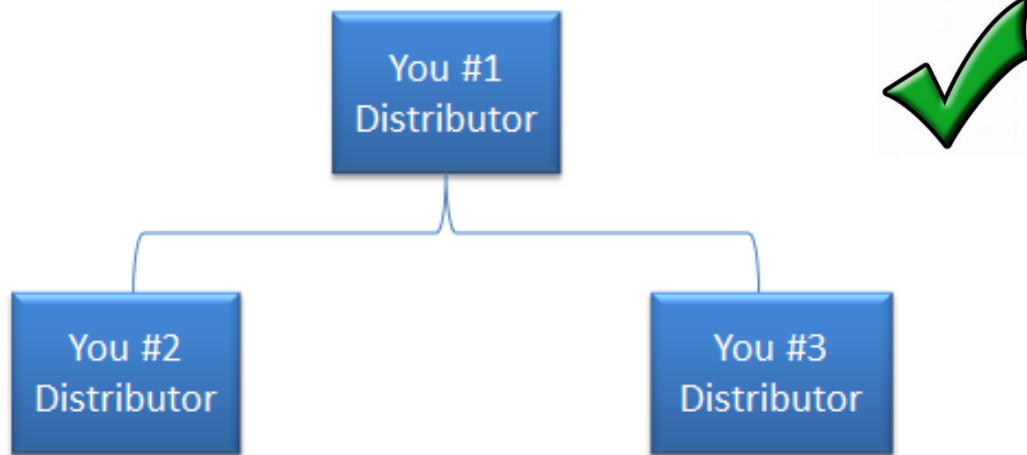

i.e. #2

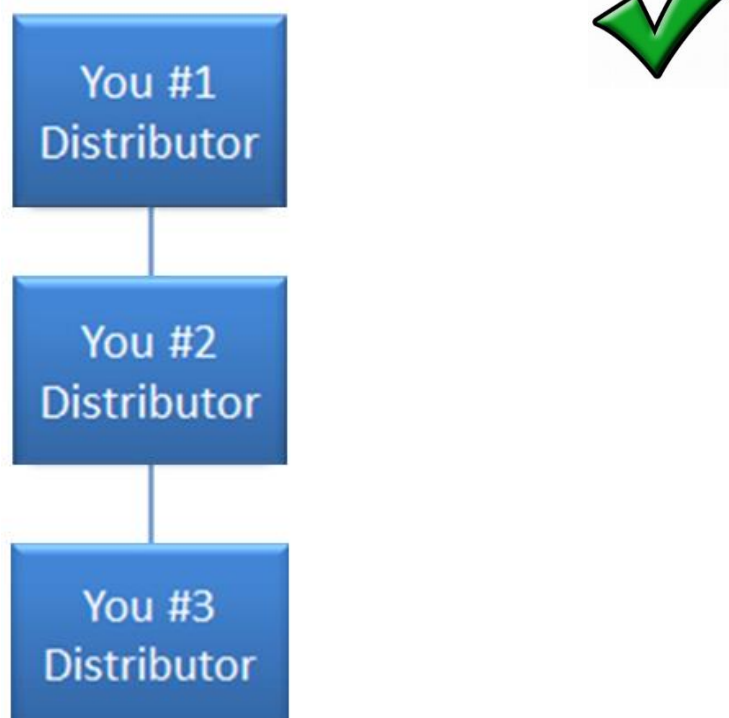



Distributor can NOT sponsor someone who has a sponsor already.

Existing distributor can NOT create the 2nd account under another different sponsor ID.

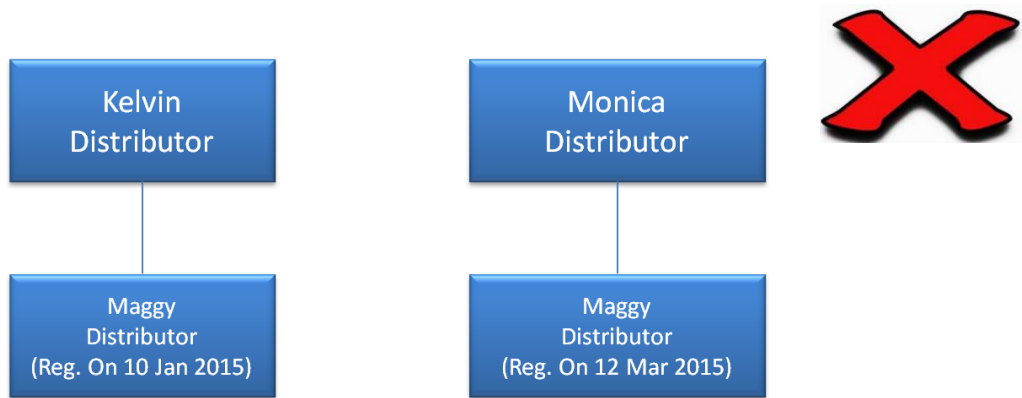

Distributor can NOT open his 2nd / 3rd ID directly under his own sponsor ID. Distributor should register his 2nd / 3rd ID directly under his own registered ID.

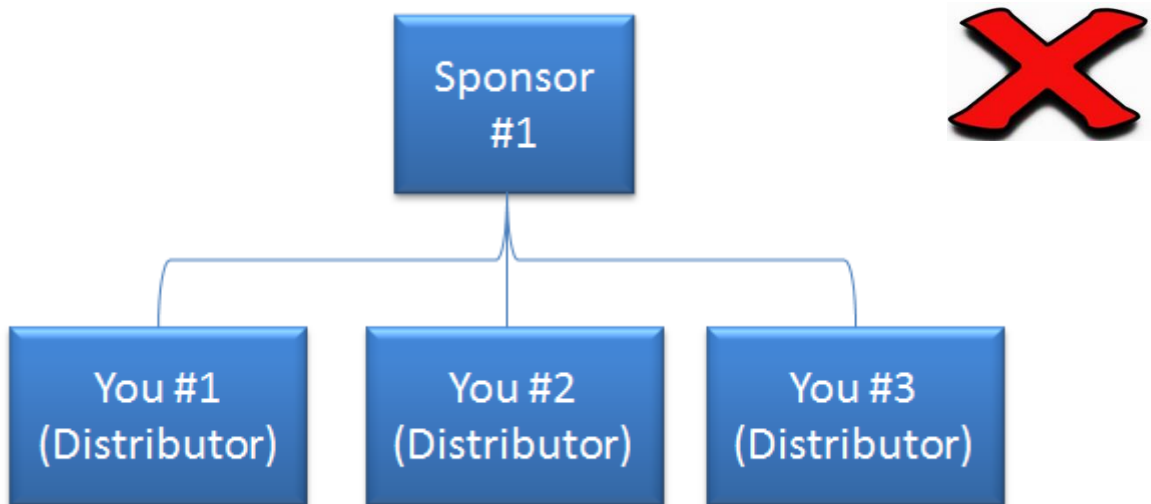



Commission Status

In addition to the Ranking System, there are 4 commission statuses that will determine how much compensation you shall receive on each sale.

SP (Special Point)

When does it apply?

When your direct sale is within 90 days of your last direct sale.

What does it mean?

You will receive a special bonus in addition to the basic commission.

D0 (Partial Status)

When does it apply?

When your last direct sale was over 06 months ago.

What does it mean?

You will only receive 50% of basic commission for your indirect sale.

D1 (Normal Status)

When does it apply?

When your last direct sale was over 90 days ago, but less than 06 months ago.

What does it mean?

You will only receive full commission for your sale, but no Special Bonus.

FAO

When does it apply?

When you have not made a direct sale within 2 years or more.

What does it mean?

You will not receive any commission and bonus while your status is FAO. Once you make a direct sale, your status will be changed to SP status.

Special Points (SP)

SP is an additional bonus payment that is used whenever a direct sale is made by a distributor (except for Tokurei distributors). Tokurei distributors will be qualified to receive SP when a direct sale is made after Tokurei is cancelled. The SP bonus last for 3 months. And will discontinue automatically unless another direct sale is made. If a direct sale is made while still in the SP bonus period, the date of expiration will be changed to three months from the date of the latest direct sale order is processed. If a sale is not made and the bonus period is allowed to stop, it can be resumed at any time by simple making a direct sale. SP is paid on all sales within 8-points during the bonus period. The payments are multiplied by rank. For example, if a person rank is 3A and sells the SD 501, he will receive AED 190 SP Bonus + AED 755 Basic Bonus multiplied by 3. So, total of AED 570 SP Bonus + AED 2,265 Basic Bonus.



Filters Commission: -

- * Filter Commission will be issued once the amount is accumulated up to AED 700.00 and above.
 - * Promotion prices are applied on filter prices on June and December annually.
 - * Filter commission does NOT have SP portion. It is only Basic.
 - * Filter commission will be paid in accordance with the 8-points commission structure to the up-lines of the filter purchaser/ applicant name and ID based on each eligible up-line rank status.
(SP & D1 accounts will receive full commission, D0 accounts will receive 50% of commission).
 - * HG Filters should be replaced every 6,000 Liter usage of the Kangen Water®.
 - * ANESPA® external cartridge should be replaced every 1 year.
 - * ANESPA® ceramic cartridge should be replaced every 2 years.
- Your use of external Pre- Filtration systems does NOT substitute for the necessity to use the special Enagic HG filter installed in the used device, and to replace it periodically, in order to ensure the quality of the water resulting from the electrolysis process.



Enagic Kangen Water® Equipment L.L.C.

Dubai

Change Your Water



Change Your Life!®

Office No. 105, Hassanico Building, Al-Barsha 1, Dubai,
United Arab Emirates.

P.O. Box: 282885

Tel: (+971) 4 395 5011

Fax: (+971) 4 395 5150

Enagic Online forms download http link

www.enagic.ae

